



Products

Classic



Description

*13" x 17" stainless steel frames
located in trendy establishments.*

Benefits

- Strategically located behind bathroom stalls, above urinals, beside mirrors and above the hand dryers.
- 100% gender specific.
- Wide range of creative possibilities (customized boards, dispensers, etc).

Networks

Available in all Newad's networks: RestoBars, Campus, Sports.

Impressions

25,634,975 weekly impressions delivered nationally. **COMB** APPROVED

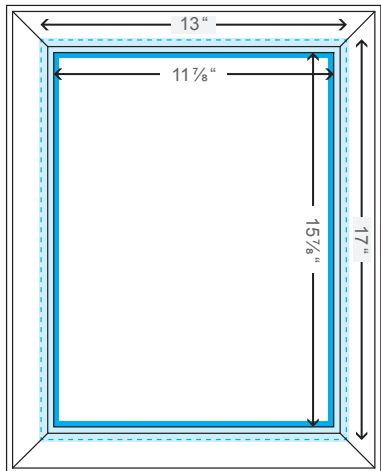

Specifications

Dimension (trim)

13" x 17"

Bleed

13 1/4" x 17 1/4"

Visible space

11 7/8" x 15 7/8"

Safe area

11 3/8" x 15 3/8"

Process suggested

100lb/200M stock paper, coated 2 sides

File format

300 dpi resolution artwork is required

newad.

indoor • experiential • publishing • web

Digital



Description

Captivate your target consumers with the combination of video and sound. Your 15-, 30-, 45-, or 60-second message is played in a loop. As well, 15-second video clips are interspersed between advertising to entertain consumers in between ads.

Benefits

- 22" LCD screen that combines both video and sounds to bring the message alive.
- Wide range of adaptable creative possibilities, including landscape format video or full-screen portrait format.

Network

550 Digitals available in Newad's RestoBars network:

- Vancouver: 92 Digitals
- Calgary: 60 Digitals
- Edmonton: 62 Digitals
- Toronto: 201 Digitals
- Montreal: 135 Digitals

Impressions

1,128,550 weekly impressions delivered nationally. **COMB** APPROVED

G3

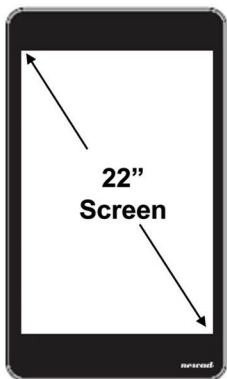

G2

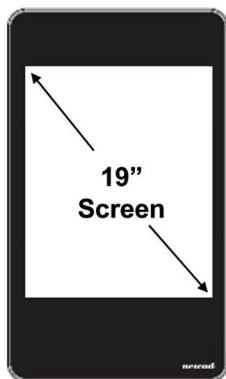

Spécifications

The specifications below apply to both 19" and 22" screens.

Dimensions

720 X 1080 pixels (width X height)

Format of Final File

MP4, H264 (including all elements of the creative)

File Size

Less than 50MB per 15 seconds

Quality

Best possible, 12 mbps maximum

Audio

48KHz / stereo / 128kbps / AAC / 48KHz

newad.

indoor • experiential • publishing • web

Backlit

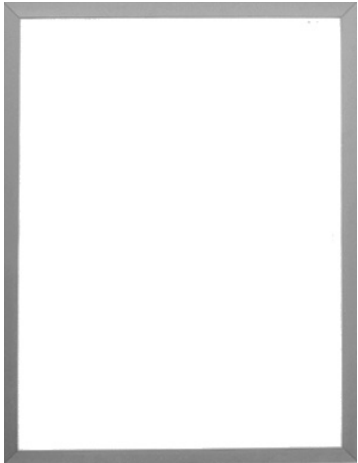

Description

2' x 3' backlit boards that create a strong impact and capture people's attention.

Benefits

- The advertising clearly stands out and catches attention.
- Strategically located in high traffic areas (restrooms, hallways, near water fountains etc.).

Networks

Available in Newad's RestoBars and Sports networks.

Impressions

1,789,500 weekly impressions delivered nationally. **COMB** APPROVED

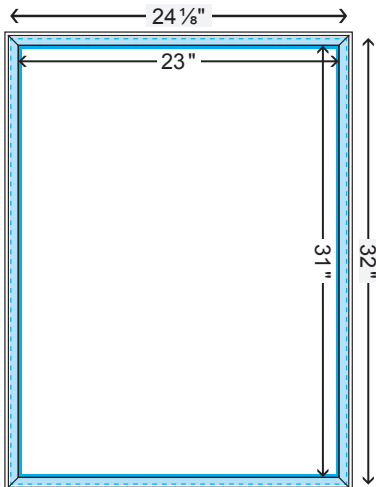

Specifications

Dimension (trim)

24 1/8" x 32"

Bleed

24 3/8" x 32 1/4"

Visible space

23" x 31" (portrait)

Safe area

22 1/2" x 30 1/2"

Paper

Materiel Polyester 7 MIL
Gloss 3 MIL

File format

150 dpi resolution artwork is required

newad.

indoor • experiential • publishing • web

Big Backlit



Description

4' x 6' backlit boards located within the top Campuses across Canada that allow you to reach millions of students each year.

Benefits

- Located in high traffic areas: hallways, cafeterias, entrances, student centers.
- Increase brand awareness as well as the quality of the message.
- Command attention and reach a large amount of students.

Network

Available in Newad's Campus network.

Impressions

5,797,000 weekly impressions delivered nationally. **COMB** APPROVED

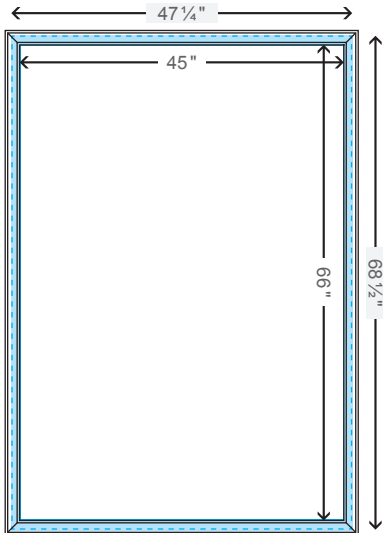

Specifications

Dimension (trim)

47 1/4" x 68 1/2"

Bleed

47 1/2" x 68 3/4"

Visible space

45" x 66" (vertical)

Safe area

44 1/2" x 65 1/2"

Paper

Material Polyester 7 MIL

Gloss 3 MIL

File format

150 dpi resolution artwork is required

newad.

indoor • experiential • publishing • web

Mega Banner 5' x 7' RestoBars

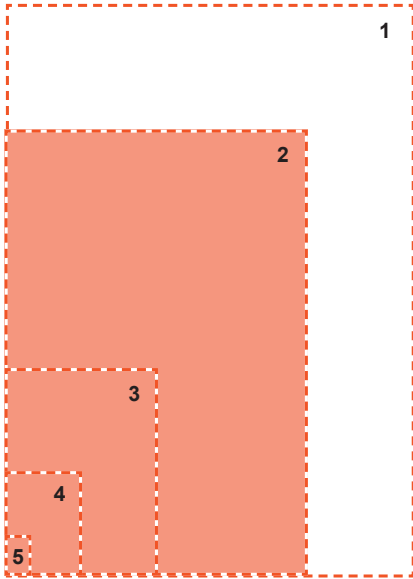

Description

Dominate the landscape with banners in RestoBars. Newad's impressive Mega Banners allow the advertiser to captivate the target consumer as the advertising clearly stands out.

Benefits

5' x 7' banners strategically located in high traffic areas.

Network

Available in Newad's RestoBars network.

Impressions

715,500 weekly impressions delivered nationally.

Specifications

Bleed

62" x 93"

Visible space

60" x 84"

Safe area

57" x 74"

- 1 Mega Banner Dimension: 5' x 7'
- 2 Big Backlit Dimension: 4' x 6'
- 3 Backlit Dimension: 2' x 3'
- 4 Classic Dimension: 13" x 17"
- 5 Post Card Dimension: 4 3/4" x 6"

File Format

Photoshop CS2, Illustrator CS2, Corel Draw 12 and Quark Express 6 or any earlier versions of these. Generic formats such as EPS, TIFF, PDF, and JPG files are also acceptable as long as they meet the criteria below.

Minimum resolution at actual size is 50 DPI, but 75-100 DPI is recommended.

Provide artwork in a PC or MAC compatible format and convert all fonts to outlines/curves, except for Quark Express where fonts will have to be supplied.

Indicate Pantone equivalents for any colours that require accurate colour matching. Provide all other colours in CMYK. Colour proofs are required in order to ensure accurate colour matching.

newad.

indoor • experiential • publishing • web

Mega Banner 7' x 5' RestoBars

Description

Dominate the landscape with banners in RestoBars. Newad's impressive Mega Banners allow the advertiser to captivate the target consumer as the advertising clearly stands out.

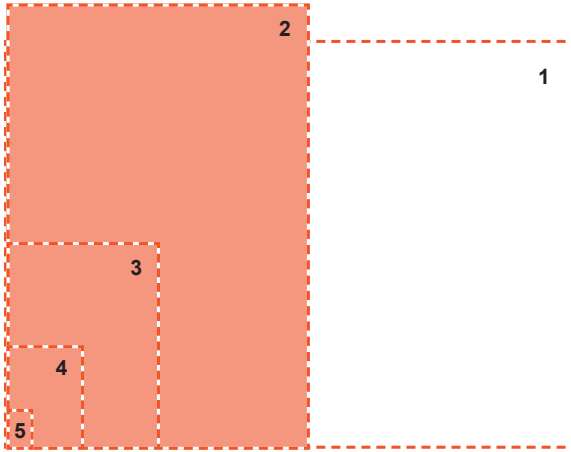

Benefits

7' x 5' banners strategically located in high traffic areas.

Network

Available in Newad's RestoBars network.

Specifications

Bleed

86" x 69"

Visible space

84" x 60"

Safe Area

81" x 50"

1 Mega Banner Dimension: 7' x 5'

2 Big Backlit Dimension: 4' x 6'

3 Backlit Dimension: 2' x 3'

4 Classic Dimension: 13" x 17"

5 Post Card Dimension: 4 1/4" x 6"

File Format

Photoshop CS2, Illustrator CS2, Corel Draw 12 and Quark Express 6 or any earlier versions of these. Generic formats such as EPS, TIFF, PDF, and JPG files are also acceptable as long as they meet the criteria below.

Minimum resolution at actual size is 50 DPI, but 75-100 DPI is recommended.

Provide artwork in a PC or MAC compatible format and convert all fonts to outlines/curves, except for Quark Express where fonts will have to be supplied.

Indicate Pantone equivalents for any colours that require accurate colour matching. Provide all other colours in CMYK. Colour proofs are required in order to ensure accurate colour matching.

newad.

indoor · experiential · publishing · web

Mega Banner 10' x 7' Campus

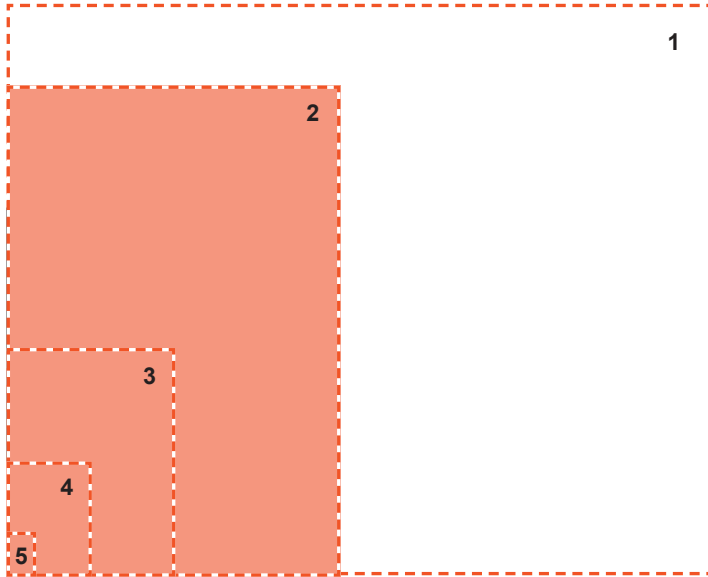

1 **Description**

Dominate the landscape with banners in the most prestigious colleges and universities all over the Canada. Newad's impressive Mega Banners allow you to connect with millions of students.

Benefits

10' x 7' banners strategically located in high traffic areas.

Network

Available in Newad's Campus network.

Impressions

1,703,000 weekly impressions delivered nationally

Specifications

Bleed

122" x 93"

Visible space

120" x 84"

Safe Area

117" x 74"

1 Mega Banner Dimension: 10' x 7'

2 Big Backlit Dimension: 4' x 6'

3 Backlit Dimension: 2' x 3'

4 Classic Dimension: 13" x 17"

5 Post Card Dimension: 4 3/8" x 6"

File Format

Photoshop CS2, Illustrator CS2, Corel Draw 12 and Quark Express 6 or any earlier versions of these. Generic formats such as EPS, TIFF, PDF, and JPG files are also acceptable as long as they meet the criteria below.

Minimum resolution at actual size is 50 DPI, but 75-100 DPI is recommended.

Provide artwork in a PC or MAC compatible format and convert all fonts to outlines/curves, except for Quark Express where fonts will have to be supplied.

Indicate Pantone equivalents for any colours that require accurate colour matching. Provide all other colours in CMYK. Colour proofs are required in order to ensure accurate colour matching.

newad.

indoor • experiential • publishing • web

Audio



Description

Consumers are highly influenced by audio & visual images combined, as the audio component adds an emotional impact that printed words alone cannot impart.

Benefits

- Stainless steel frame containing an audio file, motion activated.
- Exclusive message of 15 or 30 seconds.
- The message gets consumers on the go in an innovative way.
- Increases the reach of the product/service advertised.

Networks

Available in all Newad's networks: RestoBars, Campus, Sports.

Impressions

25,634,975 weekly impressions delivered nationally. **COMB** APPROVED

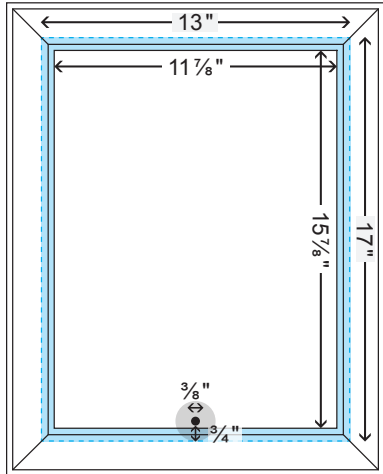

Motion detection

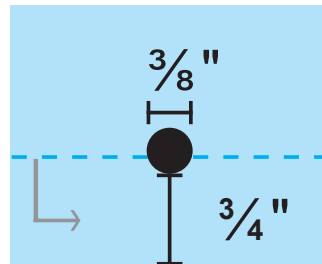

Specifications

Poster

Dimension (trim)

13" x 17"

Bleed

13 1/4" x 17 1/4"

Visible space

11 7/8" x 15 7/8"

(including a small cut-out space for the motion detector)

Process suggested

80lb/160M stock paper

File format

300 dpi resolution artwork is required

Motion detection

3/8" cut-out circle or white area* centered and 3/4" from the bottom of the poster

Sound

Format

mp3, wave

Duration

30 seconds maximum

newad.

indoor • experiential • publishing • web

Luminescent



Description

Due to an electronic current, the electroluminescent paper emits lighting that can be programmed to either illuminate certain parts of the ad or illuminate segments in sequence. Furthermore, sound can be added to the creative, playing in sequence with the illumination and when motion-activated.

Benefits

- Innovative advertising medium with a wide range of creative possibilities.
- 100% gender specific.
- Illumination can start by motion-activated sensor; by environmental sounds, such as a clap or the audio file programmed; or can be on continuously as programmed.
- These high impact boards are effective for new products or campaigns; granting their ability to isolate new features independently.

Networks

- Available in all Newad's networks: RestoBars, Campus, Sports.

Impressions

25,634,975 weekly impressions delivered nationally. **COMB**APPROVED

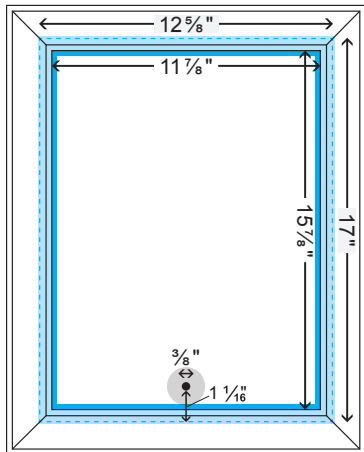

Motion detection

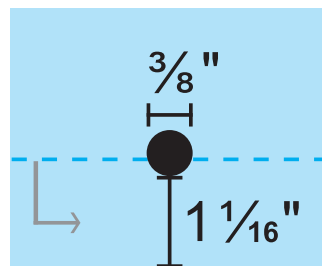

Specifications

Poster

Dimension (trim)

12 5/8" x 17"

Bleed

12 7/8" x 17 1/4"

Visible space

11 7/8" x 15 7/8"

Safety area

11 3/8" x 15 1/8"

The safety area from the bottom of the poster is 1 1/16".

Motion detection

3/8" cut-out circle centered and 1 1/16" from the bottom of the poster (TRIM Size).

Format

Adobe Illustrator vector file, 300dpi resolution artwork

Sound

Format

Wave

Duration

20 seconds maximum
(duration of 10 seconds is recommended)

Illumination and sound activation

Client to provide directions on how illumination and sound should be programmed together.

newad.

indoor • experiential • publishing • web

Lenticular



Description

Add a special touch to your advertisement with lenticular paper. Lenticular printing is a technology in which a lenticular lens is used to produce images with an illusion of depth, or the ability to change or move as the image is viewed from different angles. It is possible to obtain various effects such as 3D, animation, flips, morphing and zooms.

Benefits

- Strategically located behind bathroom stalls, above urinals, beside mirrors and above the hand dryers.
- 100% gender specific
- Create the illusion of a changing creative when it is viewed from different angles.

Networks

Available in all Newad's networks: RestoBars, Campus, Sports.

Impressions

25,634,975 weekly impressions delivered nationally. **COMB** APPROVED

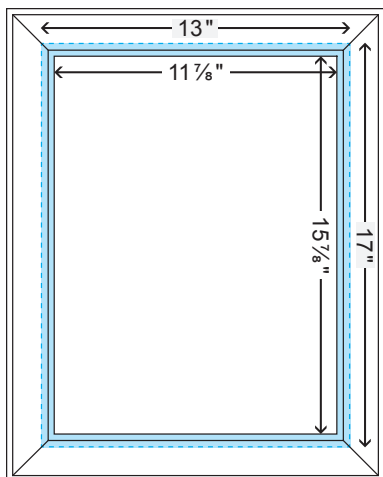

Specifications

Dimension (trim)

13" x 17"

Bleed

13 1/4" x 17 1/4"

Visible space

11 7/8" x 15 7/8"

Safety area

11 3/8" x 15 3/8"

Process suggested

100lb/200M stock paper, coated 2 sides

File format

300 dpi resolution artwork is required

newad.

indoor • experiential • publishing • web

Postcard



Description

Cards placed in a stainless steel card rack hooked underneath Classics. Ideal for coupons, take-one pads, contests, databases, invitations, Web site promotions, etc. This product allows consumers to bring the information with them.

Benefits

- Combines image, media & direct marketing experiences.
- Located in high traffic areas (restrooms, hallways, near water fountains, etc.).
- 100% gender specific.
- Quantitative results.

Networks

Available in all Newad's networks: RestoBars, Campus, Sports.

Impressions

25,634,975 weekly impressions delivered nationally. **COMB** APPROVED

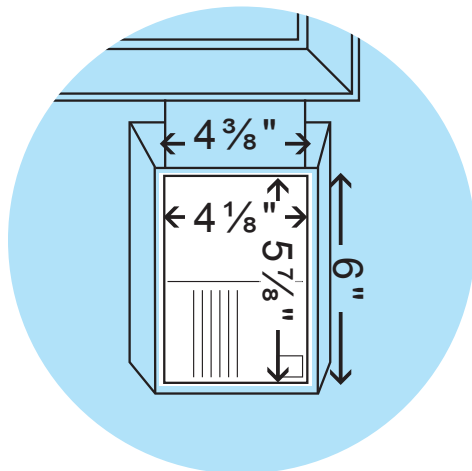

Specifications

Dimension (trim)

4 3/8" x 6"

Bleed

4 5/8" x 6 1/4"

Visible space

4 1/8" x 5 7/8"

Process suggested

4 colour process, 12 pts card stock, coated 1 side

File format

300 dpi resolution artwork is required

newad.

indoor • experiential • publishing • web